

**SLIM SMD INDUCTOR
– ES3D18P SERIES**



● **FEATURE**

1. Low profile and small size (Height: 1.8mm Max)
2. Shielding type

● **Applications**

1. LCD panels, Digital camera, PDA and others

● **Shape and Dimension**

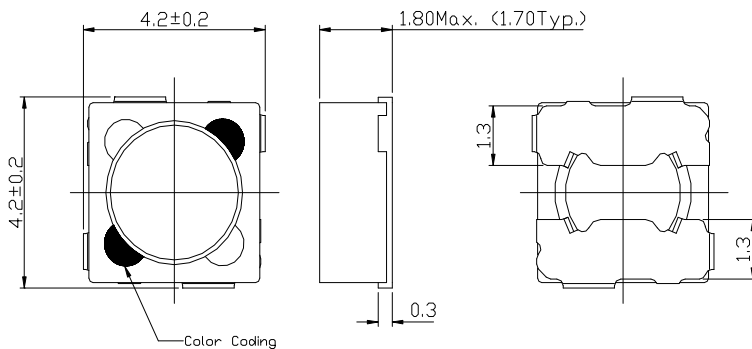

● **Schematics and Land Patterns(mm)**

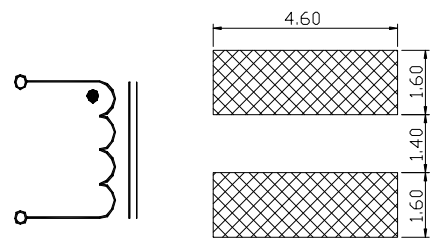

● **Specification**

Part Number	L(uH)	DOT Marking	DCR($\Omega \pm 20\%$)	Isat(A)	Irms(A)
ES3D18P-1R0M	1.0 $\pm 20\%$	BLACK	0.038	3.20	2.40
ES3D18P-1R2M	1.2 $\pm 20\%$	BROWN	0.044	3.00	2.20
ES3D18P-1R5M	1.5 $\pm 20\%$	RED	0.050	2.70	2.20
ES3D18P-1R8M	1.8 $\pm 20\%$	ORANGE	0.058	2.40	2.00
ES3D18P-2R2M	2.2 $\pm 20\%$	YELLOW	0.062	2.20	1.90
ES3D18P-2R7M	2.7 $\pm 20\%$	GREEN	0.068	2.10	1.80
ES3D18P-3R3M	3.3 $\pm 20\%$	BLUE	0.080	1.88	1.65
ES3D18P-3R9M	3.9 $\pm 20\%$	VIOLET	0.084	1.80	1.56
ES3D18P-4R7M	4.7 $\pm 20\%$	GRAY	0.099	1.46	1.40
ES3D18P-5R6M	5.6 $\pm 20\%$	WHITE	0.110	1.40	1.30
ES3D18P-6R8M	6.8 $\pm 20\%$	BLACK	0.128	1.26	1.20
ES3D18P-8R2M	8.2 $\pm 20\%$	BROWN	0.146	1.24	1.15
ES3D18P-100M	10 $\pm 20\%$	RED	0.165	1.10	1.05
ES3D18P-120M	12 $\pm 20\%$	ORANGE	0.254	1.00	0.80
ES3D18P-150M	15 $\pm 20\%$	YELLOW	0.320	0.88	0.72
ES3D18P-180M	18 $\pm 20\%$	GREEN	0.360	0.84	0.68
ES3D18P-220M	22 $\pm 20\%$	BLUE	0.418	0.74	0.65
ES3D18P-270M	27 $\pm 20\%$	VIOLET	0.450	0.70	0.60
ES3D18P-330M	33 $\pm 20\%$	GRAY	0.620	0.58	0.58

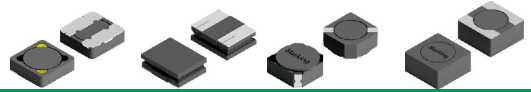
**SLIM SMD INDUCTOR
– ES3D18P SERIES**

Part Number	L(uH)	Marking	DCR($\Omega \pm 20\%$)	Isat(A)	Irms(A)
ES3D18P-390M	39 $\pm 20\%$	WHITE	0.650	0.56	0.48
ES3D18P-470M	47 $\pm 20\%$	BLACK	0.790	0.52	0.45
ES3D18P-560M	56 $\pm 20\%$	BROWN	0.862	0.48	0.40
ES3D18P-680M	68 $\pm 20\%$	RED	1.000	0.40	0.36
ES3D18P-101M	100 $\pm 20\%$	YELLOW	1.380	0.32	0.36
ES3D18P-151M	150 $\pm 20\%$	YELLOW	2.410	0.24	0.32
ES3D18P-181M	180 $\pm 20\%$	VIOLET	3.420	0.24	0.29
ES3D18P-221M	220 $\pm 20\%$	RED	3.900	0.23	0.29
ES3D18P-331M	330 $\pm 20\%$	ORANGE	5.170	0.18	0.24
ES3D18P-471M	470 $\pm 20\%$	GREEN	8.420	0.15	0.19
ES3D18P-681M	680 $\pm 20\%$	BLUE	10.30	0.13	0.16
ES3D18P-102M	1000 $\pm 20\%$	BLACK	15.20	0.10	0.13

Note1. Measurement frequency of Inductance value : at 1KHz, 1V

Note2. Measurement ambient temperature of L, DCR and IDC : at 25°C

Note3. Isat : The rated current indicates the current when the inductance decreases 35% Max from nominal value

Note4. Irms: D.C. current when at $\Delta t=30^\circ\text{C}$ (typ.), ($T_a=20^\circ\text{C}$)

Note5. Inductance tolerance: M: $\pm 20\%$

Note6. Packaging: Taping ; Quantity: 1000 Piece/reel



GENERAL CHARACTERISTICS

1. Operating temperature range: -40 TO + 105°C (Includes temperature when the coil is heated)
2. External appearance: On visual inspection, the coil has no external defects.
3. Terminal strength: After soldering. Between copper plate and terminals of coil. Push in two directions of X.Y withstanding at below conditions.

Terminal should not peel off. (refer to figure at right) 5. 0N 60 sec.

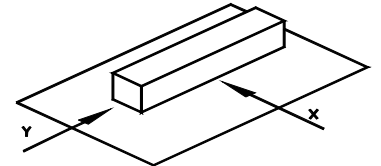

4. Insulating resistance: Over 100MΩ at 100V D.C. between coil and core.
5. Dielectric strength: No dielectric breakdown at 100V D.C. for 1 minute between coil and core.
6. Temperature characteristics: Inductance coefficient $(0\sim 2,000)\times 10^{-6}/^{\circ}\text{C}$ (-25~+80°C degree Celsius), inductance deviation within $\pm 5.0\%$, after 96 hours.
7. Humidity characteristics(Moisture Resistance): Inductance deviation within $\pm 5\%$, after 96 hours in 90~95% relative humidity at $40 \pm 2^{\circ}\text{C}$ and 1 hour drying under normal condition.
8. Vibration resistance: Inductance deviation within $\pm 5\%$, after vibration for 1 hour. In each of three orientations at sweep vibration (10~55~10 Hz) with 1.5mm P-P amplitudes.
9. Shock resistance: Inductance deviation within $\pm 5\%$, after being dropped once with 981m/s² (100G) shock attitude upon a rubber block method shock testing machine, in three different orientations.
10. Resistance to Soldering Heat: 260°C, 10 seconds(See attached recommend reflow)
11. Storage condition: Temperature Range: 0°C ~ 35°C ; -40°C ~ 105°C (after PCB) , Humidity Range: 50% ~ 70% RH
12. Use components within 12 months. If 12 months or more have elapsed, check solderability before use.
13. Reflow profile recommend:

Lead-free heat endurance test

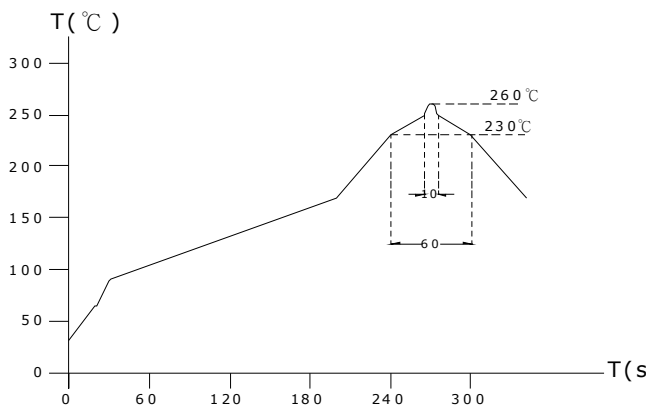

Lead-free the recommended reflow condition

